

SuperKEKB upgrade plans & International Task Force

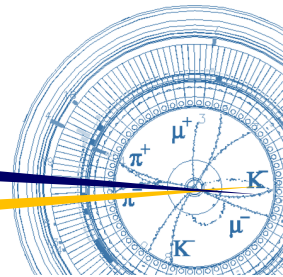

BPAC

Kyo Shibata (KEK Accelerator Laboratory)

2022.02.22



Challenges as a luminosity frontier machine

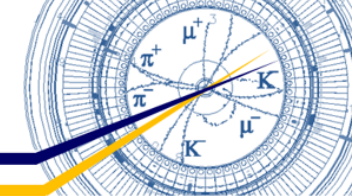

Challenges recognized in recent commissioning



- To improve the machine further to achieve the goal, however, various challenges as follows should be solved:
 - 1) **Severe beam-beam effect (vertical beam size blow-up)**
 - Vertical beam size (vertical emittance) blow-up has been observed at high bunch currents.
 - Relaxed by the crab-waist collision scheme, but it still remains.
 - 2) **Shorter beam lifetime than expected in the design phase.**
 - The maximum bunch currents are limited by the balance between the lifetime and the injection power.
 - The dynamic aperture is very small due to the beam-beam effect and crab-waist sextupoles, while the physical aperture is limited by the beam collimators.
 - 3) **Lower bunch-current limit due to TMCI than expected.**
 - The cause is higher impedance of beam collimators, where the apertures are smaller than the design values to suppress high background to Belle II.
 - 4) **Low machine stability**
 - Abnormal beam aborts, sometimes leading to the damage of collimators.
 - Operation efficiency during 2021ab, for example, was almost 0.5, lower than expected one, 0.65. (Main causes: machine tunings, machine troubles, maintenance, etc.).
 - 5) **Aging of hardware and facilities, and so on.**

2021/9/2

4

Y. Suetsugu (2021.09.02)
The 25th KEKB Accelerator
Review Committee

+ 6) **Low injection efficiency especially in HER.**



Countermeasures against challenges

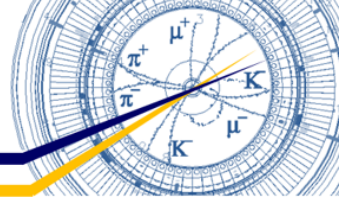

Y. Suetsugu (2021.09.02)
The 25th KEKB Accelerator Review Committee

- Major countermeasures discussed so far.
 - See Appendix C for some details.

Aim	Possible countermeasures	
(1) • Increase injection power (efficiency)	Linac upgrade to designed specification	
	Large physical aperture at electron injection point (HER)	← LS1
	Linac upgrade beyond designed specification	
(2) • Relax beam-beam effect • Expand dynamic aperture	Utilizing rotatable sextupole magnets (LER)	← After LS1? (if necessary)
	“Perfect matching”	← After LS1? (under consideration)
	QCS modification (Option#1): Move QC1RP to the far side of IP	
	Larger scale QCS modification (Option #8)	
(3) • Suppress BG • Expand physical aperture	QCS cryostat front panel modification and additional shield to IP bellows	← LS1
	Optimization of collimator location	← Done
	Enlargement of QCSR beam pipe (Option#3)	
(4) • Relax TMCI limit	“Non-linear collimator”	← LS1? (under consideration)
(5) • Improve stability	Robust collimators	← Done (partially)
	Upgrade of beam abort system and loss monitor system	← LS1 (already started)
(6) • Anti-aging measures	Preparation of standby machines and spares, repair of facilities, etc.	← LS1 (already started)

Revised schedule

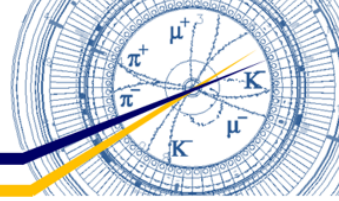

Until JFY2023 (until the end of March 2023)

- 2022a Run : 21/Feb. ~ 31/Mar.
- 2022b Run : 1/Apr. ~ 30/Jun.
- 2022 Summer Shutdown : Jul. ~ Sep.
- 2022c run : Oct. ~ Dec.
- Long shutdown 1 (LS1):

10 months from Jun. 2023

New LS1:
Jul. 2022
~ Sep. 2023

- ✓ Due to rise in electric bill, 2022c run is cancelled.
- ✓ Start time of LS1 is advanced to Jul. 2022

Subsequent schedule

- International Task Force (ITF) is considering how to increase luminosity.
- If upgrades that require a long shutdown is needed, we will have LS2 after 2026.

Half a year delay (2022/2/2)

FY	2021												2022			Total						
	4	5	6	7	8	9	10	11	12	1	2	3										
FY2021	2021b → ~3.2M						← 2021c ~2.2M			← 2022a ~1.2M			~6.6M/y									
FY2022	2022b → ~3.2M			QCSR leak check									LS1 (PXD, TOP exchange)			~3.0M/y						
FY2023				LS1 (PXD, TOP exchange)						← 2023c ~2.9M			← 2024a ~2.9M			~5.8M/y						
FY2024	2024b → ~3.4M									← 2024c ~2.4M			← 2025a ~1.2M			~7M/y						
FY2025	2025b → ~3.4M									← 2025c ~2.4M			← 2026a ~1.2M			~7M/y						
FY2026	2026b → ~3.4M									← 2026c ~2.4M			← 2027a ~1.2M			~7M/y						
													LS2									

If LS2 is required, we will have it after JFS 2026.



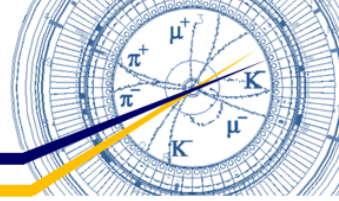

Upgrade items until LS2

• Possible countermeasures in LS1

Aim	Possible countermeasures	Expected improvement	Ready status	Current status	
				LS1	LS2
				2021	2022 2023 2024 2025 2026 2027 2028 2029 2030 2031~
Increase injection power (efficiency)	Large physical aperture at electron injection point (HER)	HER Injection rate x #?	Need further estimation, simulation, design of beam pipes	← Will be done in LS1. (Discussed later)	
Expand dynamic aperture	"Perfect matching"	LER beam lifetime (Touscheck) x ~1.5.	Need further simulation, design, manufacturing of magnets and pipes	← It may be possible without hardware upgrade. Machine study is necessary, but it turned out to be difficult and time consuming.	
Expand physical aperture Suppress BG	QCS cryostat front panel modification and additional shield to IP bellows	Background, Physical aperture, TMCI limit x ~1.2	Production is on going. Will be ready by 2022.	← Will be done in LS1 (Discussed later)	
Expand physical aperture Suppress BG	Optimization of collimator location	Background x ~1/2 (Storage beam)	On going. Need further simulation.	← Done in 2021 summer shutdown. Its effect was confirmed in 2021c.	
Relax TMCI limit	"Non-linear collimator"	TMCI limit x~2 Background x ~1/2 (Storage beam)	Need further simulation, design, manufacturing of magnets and pipes. Production of PS has started.	← Machine studies in 2022ab is required in deciding whether to install an NLC in LS1. (Discuss later)	
New Improve stability	injection kicker modification			← Countermeasures against "undesirable residual kick" and "kicker-pulser misfiring". Will be done partially in LS1. (Discussed later)	

New

• High-priority countermeasures before LS2

Aim	Possible countermeasures	Expected improvement	Ready status	Current status	
				LS1	LS2
				2021	2022 2023 2024 2025 2026 2027 2028 2029 2030 2031~
Increase injection power (efficiency)	Linac upgrade to designed specification	Full spec injection (both power and quality)	On going sequentially.	← Machine study was done in 2021c. It was turned out that the rotatable magnets are useful to relax beam-beam effect. No hardware update will be required.	
Relax beam-beam effect	Utilizing rotatable sextupole Magnets	Beam-beam parameter (emittance), beam lifetime	Ready. Need preparation of tuning knob. Knob tuning will be tried during 2021c.	← Trial model of robust collimator was installed in 2021 summer shutdown. Beam test will continue in following runs.	
Improve stability	Robust collimator	Sustainability	On going sequentially. Need more R&D and beam test	← Already started.	
Improve stability	Upgrade of beam abort system and loss monitor system	Operation stability	On going sequentially with Belle II group.	← Already started.	
Anti-aging measures	Anti-aging measures	Operation efficiency (standby machine, repair of facilities)	On going sequentially. Especially for long shut down periods	← Under consideration by ITF. (Discussed later)	

• Upgrades during and after LS2



Under consideration by ITF. (Discussed later)



Aperture enlargement of HER injection channel 1

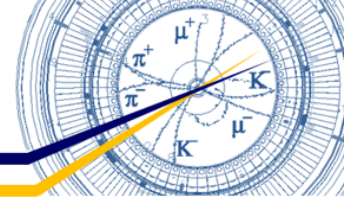

- HER injection efficiency should be improved.
 - Injection of HER beam is unstable.
 - Stable physics run requires stable injection.
 - Low injection efficiency can limit the maximum beam current.
 - Understanding of injection became deeper during 2021c.
 - It was turned out that horizontal aperture of injection channel should be enlarged to improve injection efficiency.
 - To enlarge aperture of injection channel, beam pipes around HER injection point will be replaced new ones during LS1.

LER injection status during 2021c

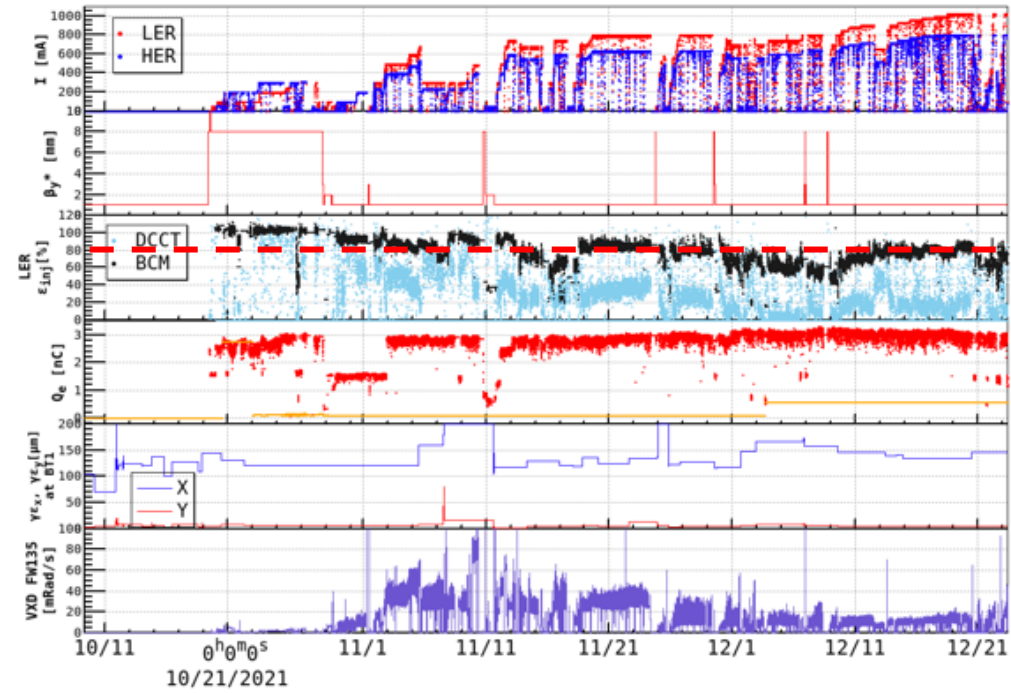

HER injection status during 2021c

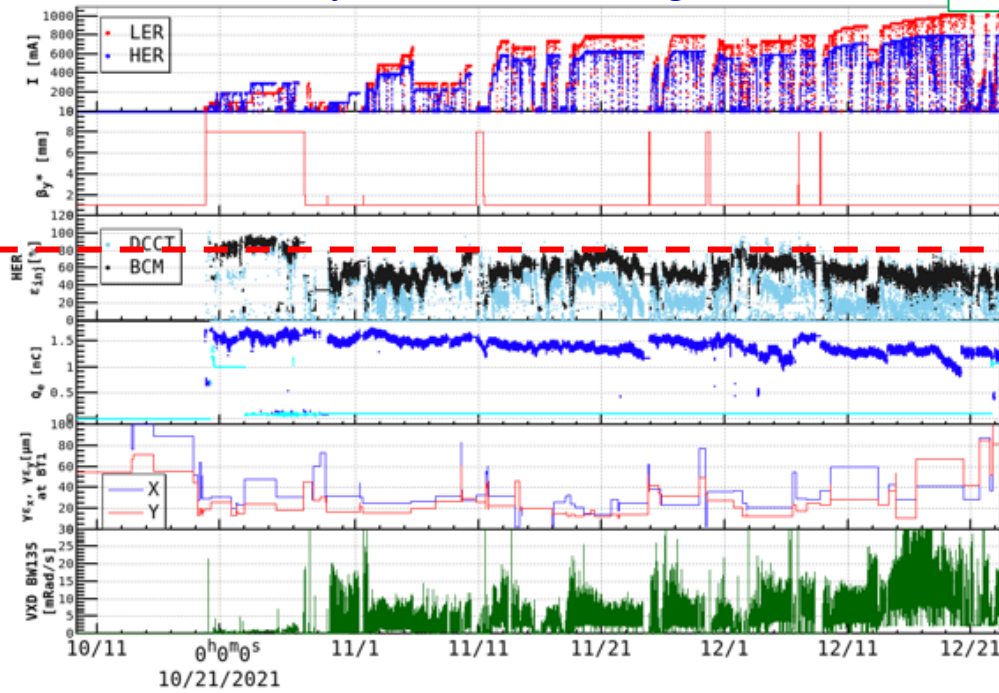

N. Iida (2022.1.21) BITF meeting

← Our target is 80%.

Aperture enlargement of HER injection channel 2

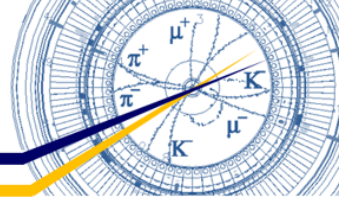

- Problem of HER injection
 - Wall can be an obstacle to injection.
 - A wall should be placed between beam channels for stored beam and injected beam.
 - Injected beam orbit is too close to the wall.
 - High levels of radiation detected at the injection BPM chamber indicates that the injected beam hits the wall.
 - It is hard to modify the injection beam orbit.
- ⇒ it is necessary to enlarge the horizontal aperture of the injection channel.

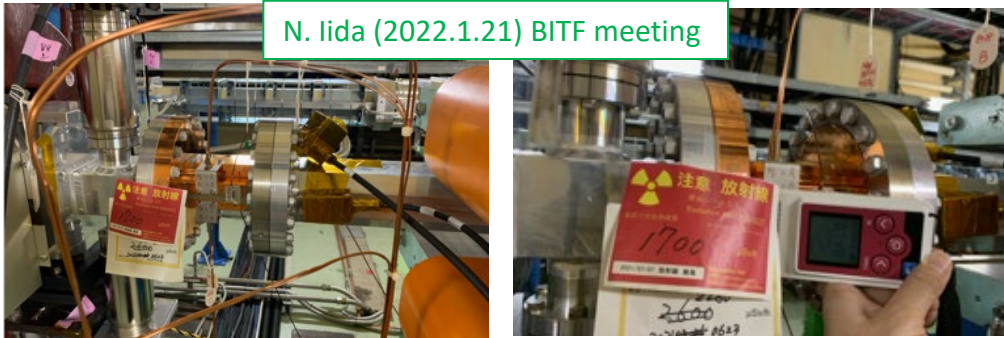

N. Iida (2022.1.21) BITF meeting

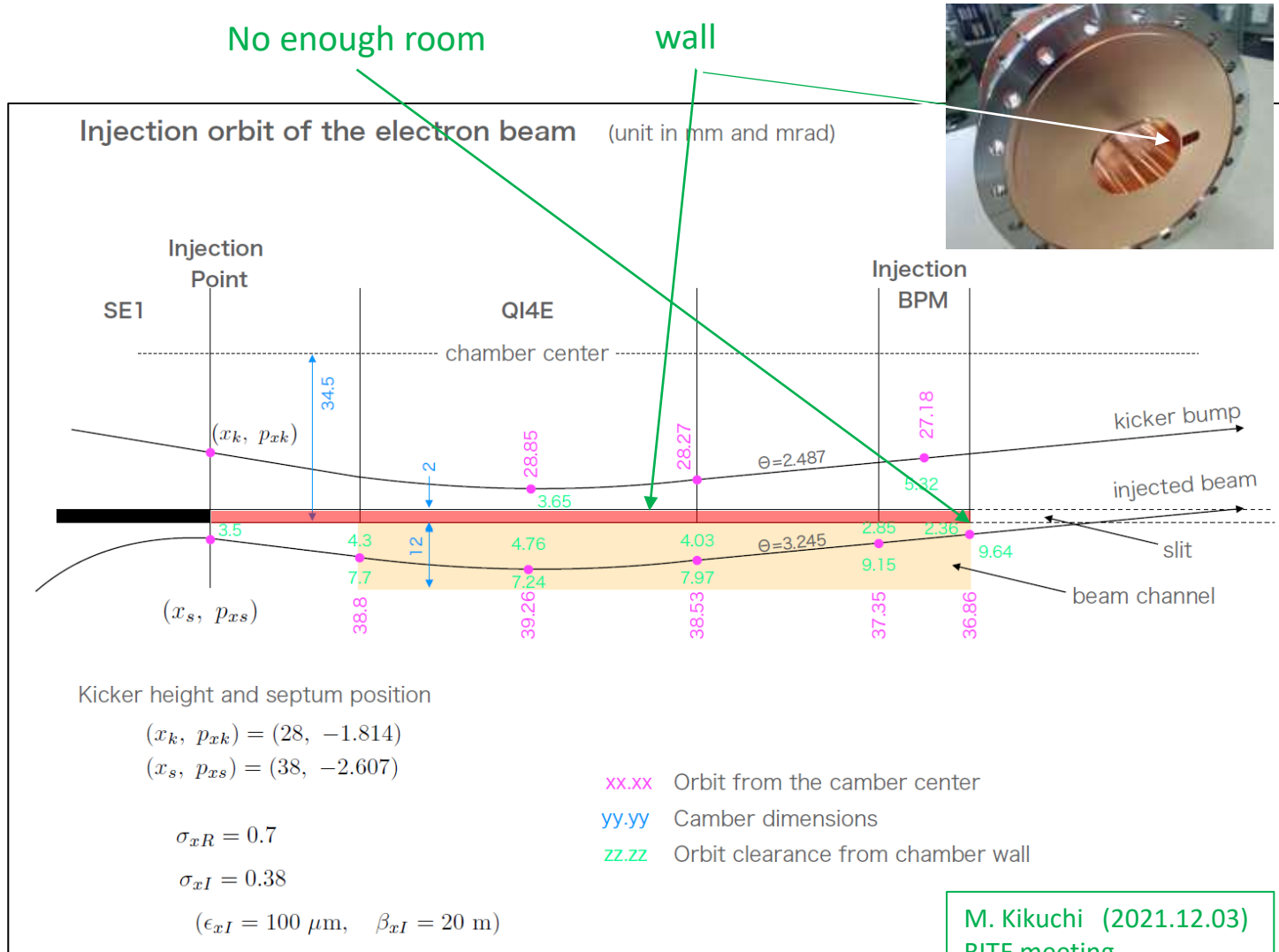

M. Kikuchi (2021.12.03) BITF meeting

- What is planned during LS1
 - Replacement of three beam chambers with new ones.
 - Update of injection BPM
- ⇒ More precise injection tuning

IR radiation shield modification 1

KEK (High Energy Accelerator Research Organization)

Modification of IR shielded during LS1

- Still the beam BG is not under control enough, and the TOP and CDC background can limit the beam currents.

- Three main BG spots in MC:

1. Crotch area of IP chamber → No enough space to put additional shield...

2. Bellows pipes → Add shields around bellows (Bellows shield) being developed by K. Nakamura

3. QCS heavy metal head plates

→ Change the QCS head material from heavy metal to SS being prepared by the vacuum and QCS groups

- Also, additional PE neutron shields around QCS are planned to mitigate frequent SEU in the CDC and ARICH.

being developed by S. Tanaka and H. Yamaoka

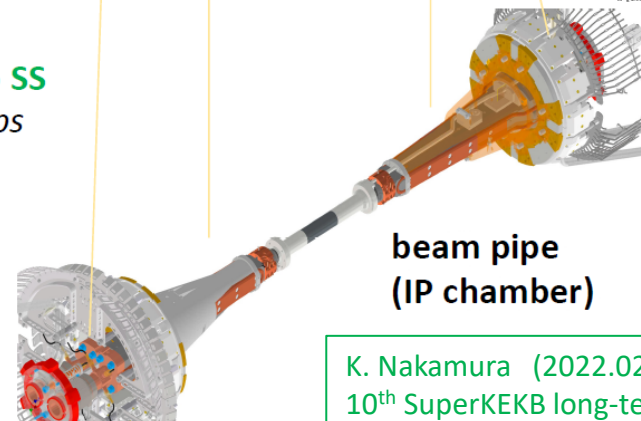
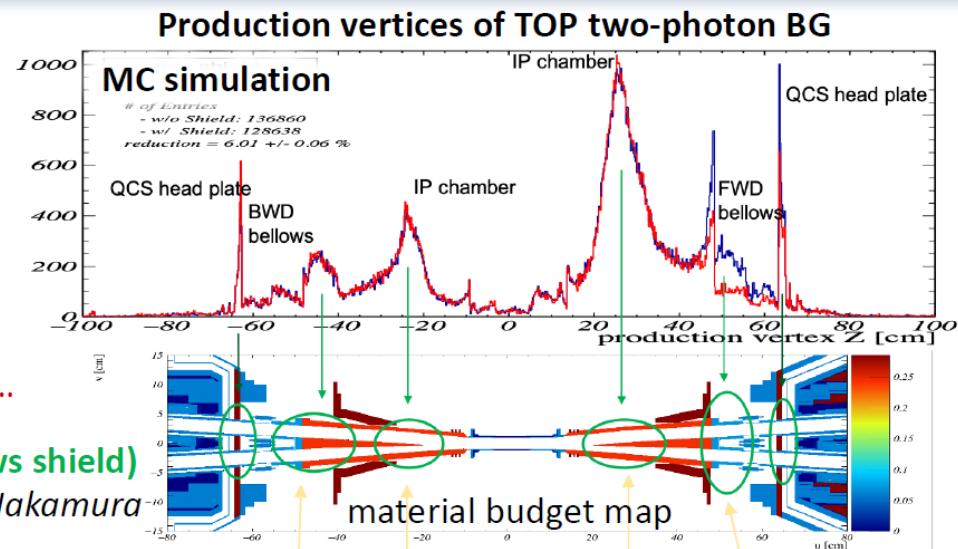

K. Nakamura (2022.02.03)
10th SuperKEKB long-term operation plan meeting

IR radiation shield modification 2

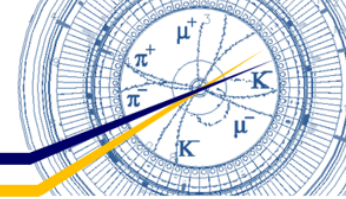

Implementation on Geant4 Geometry

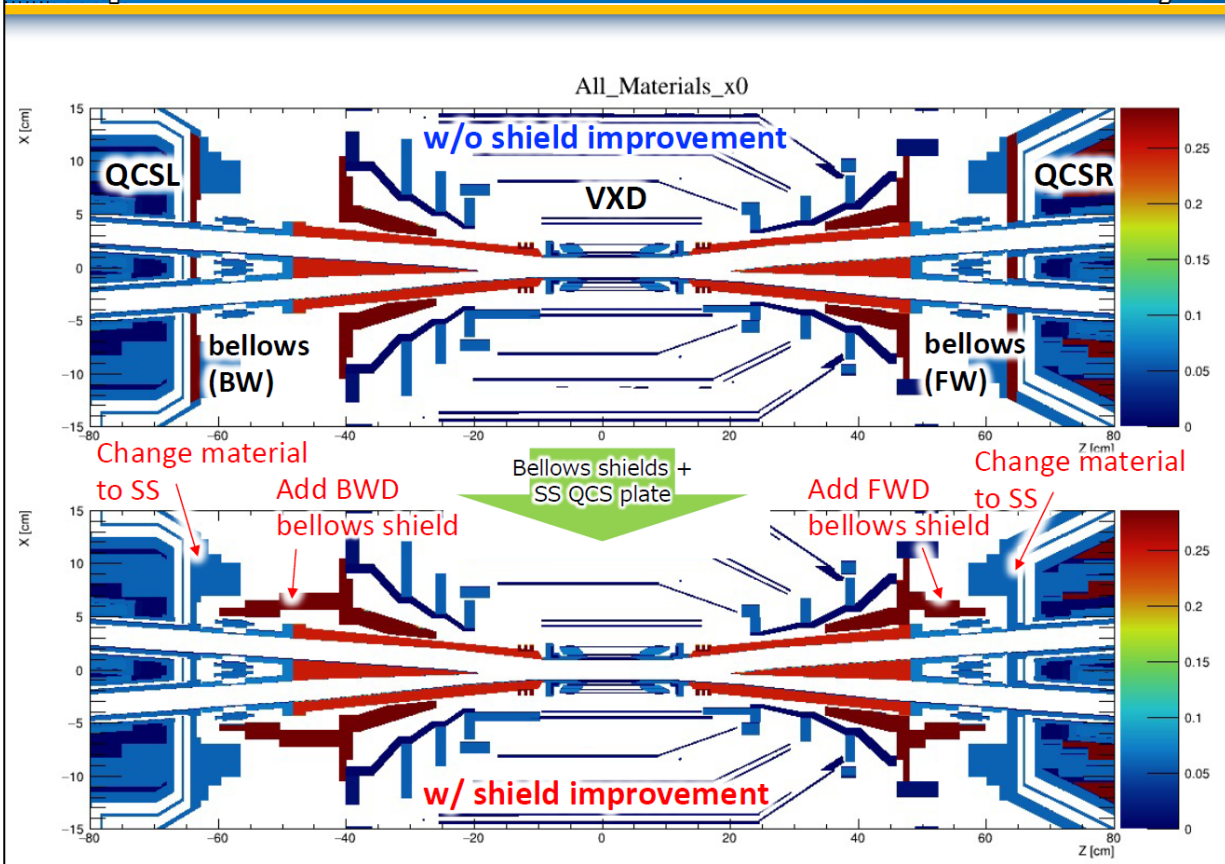

- **Additional shields reduce the beam BG of CDC and TOP well.**
 - CDC: 13%~30% for single beam BG, 30~50% for luminosity BG
 - TOP: about 20% for both single beam BG and luminosity BG
- **No bad signature on the beam BG of PXD and SVD.**

K. Nakamura (2022.02.04)
10th SuperKEKB long-term
operation plan meeting

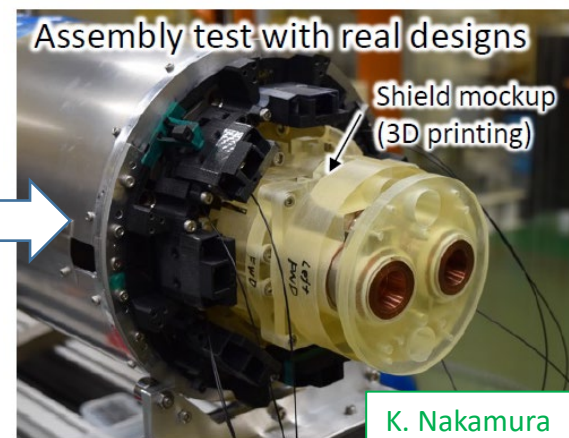
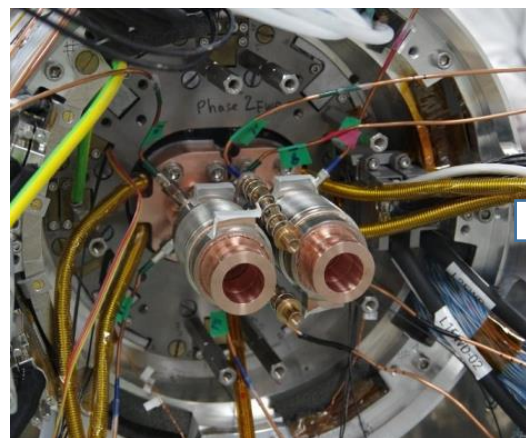

New heavy metal shield on IP bellows

K. Nakamura

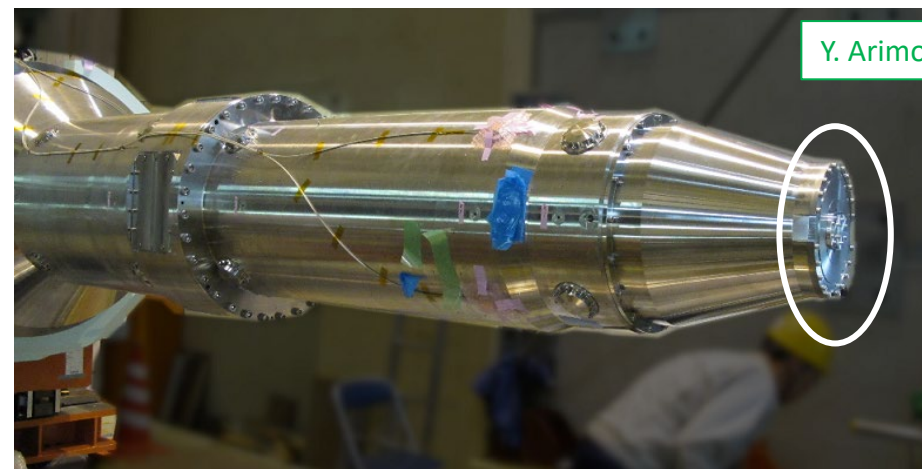

Y. Arimoto

Material change from W to SUS (QCS cryostat front plate)
(Tip of QCS cryostat will be modified to make more space)

IR radiation shield modification 3

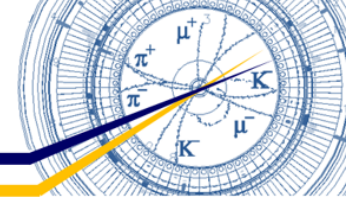

- Additional concrete shield (IR) & polyethylene shield (Belle2)

- For shielding fast neutrons

- New concrete shields and polyethylene (PE) shield will be added to a space that currently has no shield.
- Additional PE shields around QCS are also planned.

- Expected effects of shield modification

- Physics run with wider collimator setting
- Physics run with larger total currents and bunch current

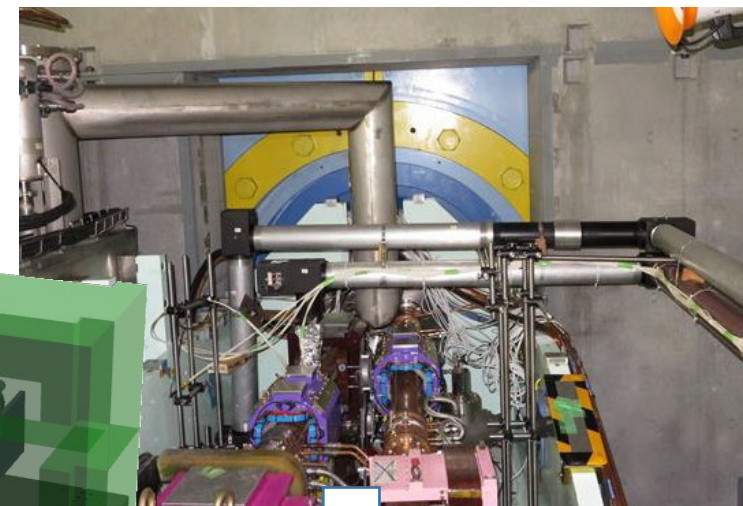

Add concrete shields

shield mockup

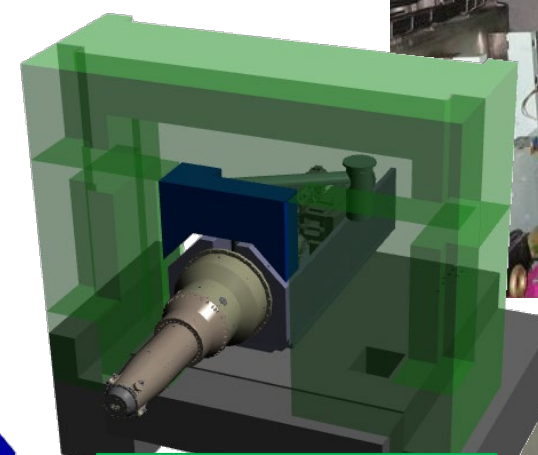

H. Yamaoka (2021.11.04)
IR meeting

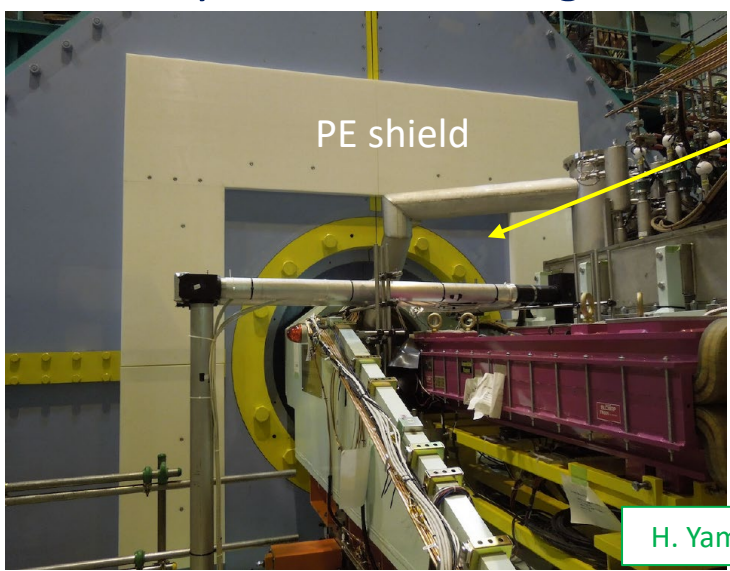

PE shield

Add PE shields

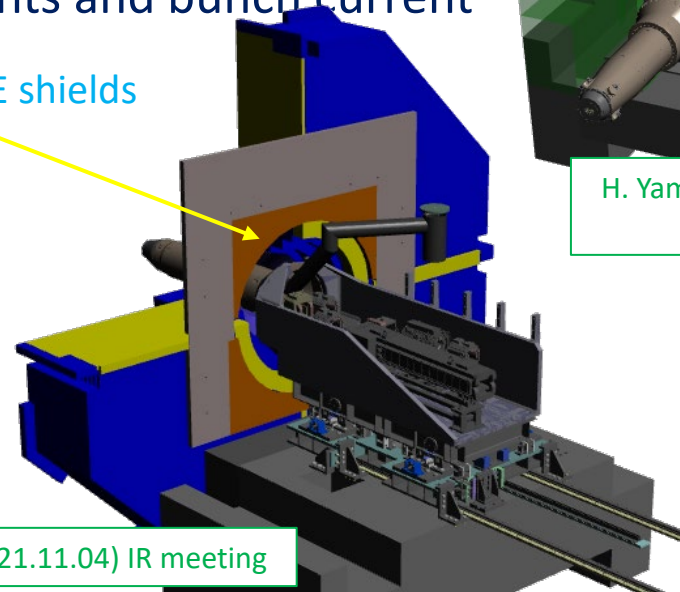

H. Yamaoka (2021.11.04) IR meeting

Non-linear collimator 1

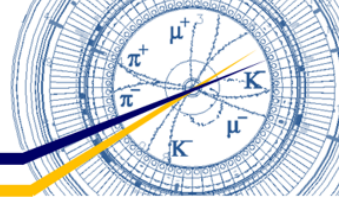

K. Oide (2021.05.14)
The 7th long-term operation plan meeting

New non-linear collimation (NLC) scheme less likely to cause TMCI

- Non-linear kick by skew sextupole magnet can make a vertical displacement at the collimator.
 - It is possible to open the collimator wider.
 - It is possible to place the collimator at larger beta-function.

⇒ It is possible to relax TMCI bunch current limit.

- NLC will be constructed at OHO straight section.
 - 50 wiggler magnets need to be removed.
 - 2 skew sextupole magnets and 5 quadrupole magnets need to be installed.
 - New magnet power sources and cabling works are required.
 - New collimator and beam pipes are also required.

Further development and study of NLC scheme is needed.

- Consideration of the effect of the removal of some wiggler sections.
- Quantification of its implications on beam optics and beam dynamics.

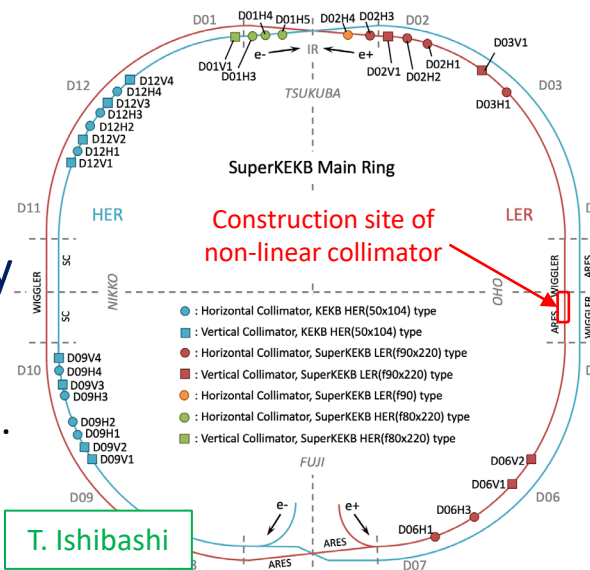

T. Ishibashi

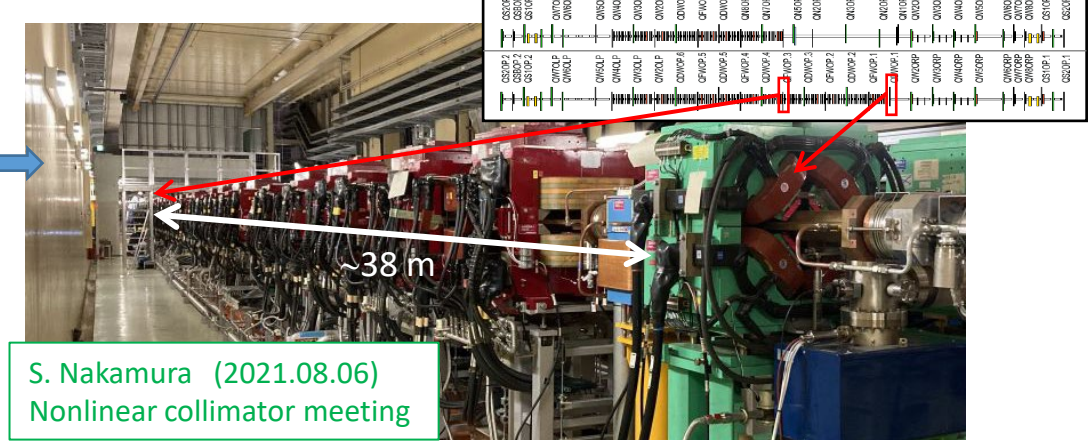
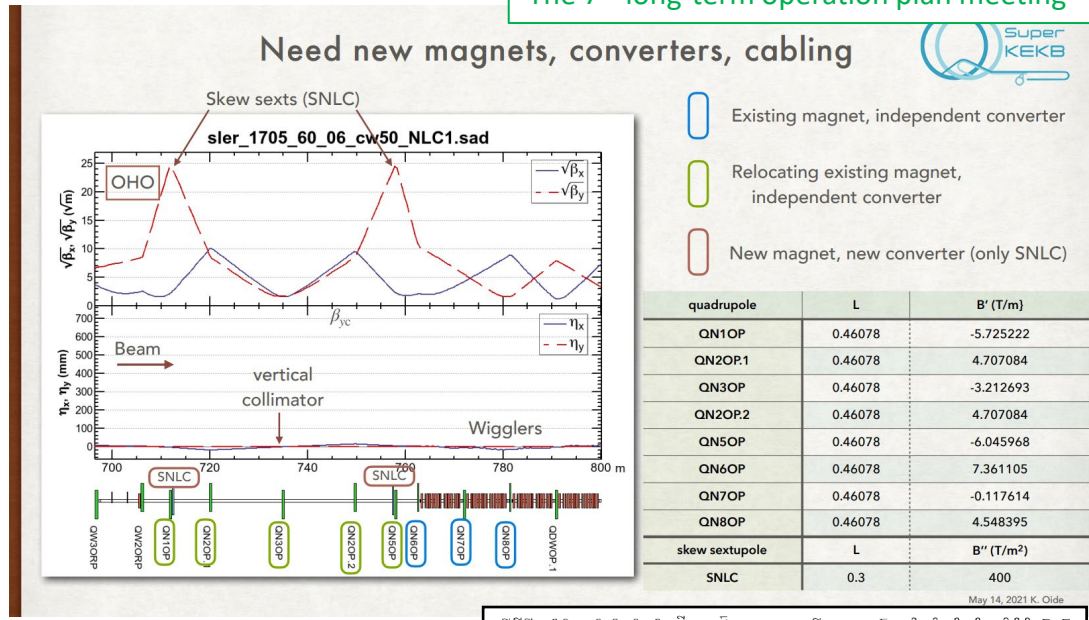

S. Nakamura (2021.08.06)
Nonlinear collimator meeting

Non-linear collimator 2

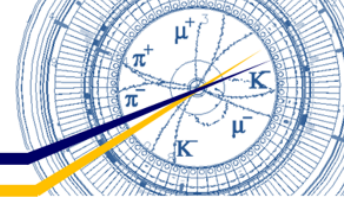

- Understanding of NLC scheme has advanced in 2021c, but further study is required.
 - It was turned out that beam blow-up becomes remarkable when β_y^* (vertical β -function at IP) is squeezed.
 - Vertical β -function (β_y) at collimator and impedance (kick factor k) of collimator do not depend on β_y^* . ($\Sigma k\beta$ of collimators does not depend on β_y^* .)
 - Is beam blow-up is caused by ordinal TMCI, which occurs when $\Sigma k\beta$ becomes larger than the threshold?
 - It seems that there are other impedance sources, that increase $k\beta$ when β_y^* is squeezed.
- ⇒ Possible candidate : Tapered beam pipes for the beam final focus system (QCS) at IR



Tapered QCS beam pipe

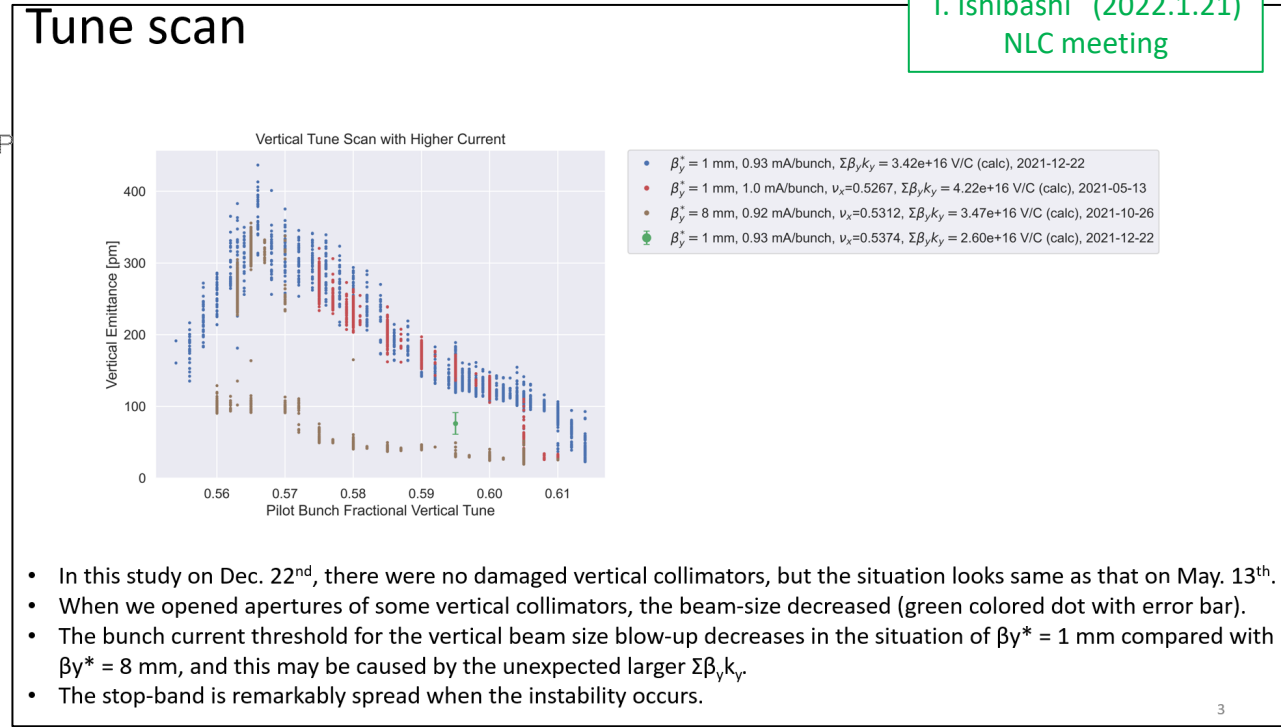
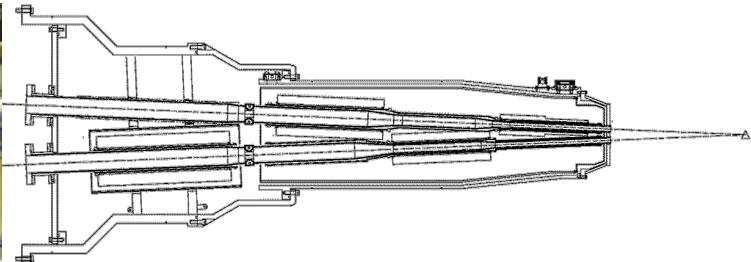

T. Ishibashi (2022.1.21)
NLC meeting

- Further machine studies in 2022ab is needed in deciding whether to install an NLC.
 - Impedance measurement of QCS beam pipes
 - Investigation of the countermeasure against beam blow-up other than NLC
 - And so on.
 - Final decision will be made around May 2022.

Injection Kicker modification 1

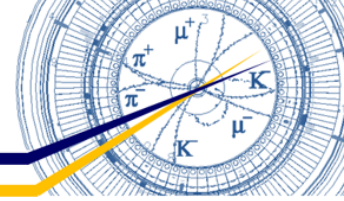

- Problems with the injection kickers (mainly for LER)

- Undesirable residual kick due to difference in magnetic field waveforms between K1 kicker and K2 kicker

Causes;

- Difference in ceramic chamber profile for each kicker.
- Difference in waveform of current supplied to each kicker.

Countermeasure;

- Waveform tuning of current supplied to K2 (2022ab)
 - Magnetic field waveform of K2 is adjusted to be the same as K1 by adding inductance.
- Replacement of K1 ceramic chambers with same ones as K2 (LS1 if necessary)

- Kicker-pulsar misfiring and resulting destruction of collimator

Causes;

- Thyratron misfiring
- Fake trigger signal due to noise
- Trigger amplifier unit failure
- Malfunction of Event Receiver

Countermeasures;

- Thyratron replacement with new ones with higher breakdown voltage
- Update to noise-resistant trigger system
- Robust collimator head (ex. carbon collimator)

Drastic countermeasures :

- “Double kicker system” where K1 and K2 kickers are driven by one power supply
- Replacing thyratrons with semiconductor switches

Translation from
T. Mimashi's slide

Injection Kicker modification 2

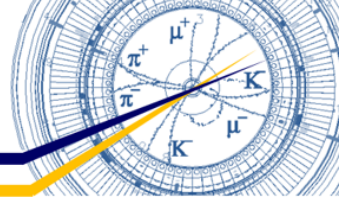

T. Mimashi

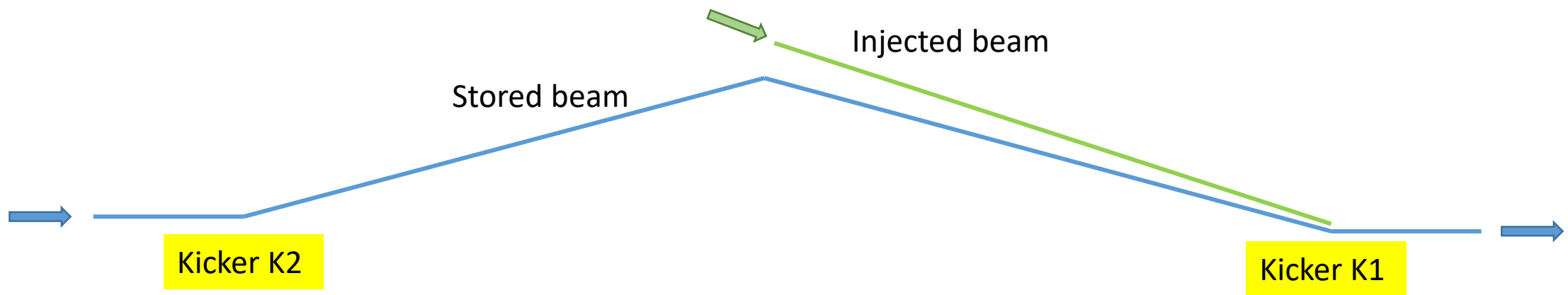
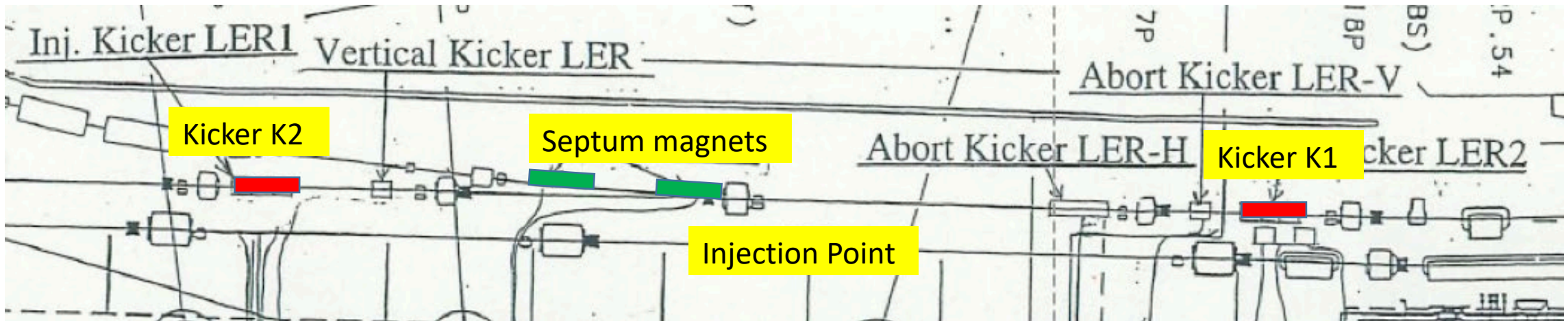

Injection Kicker modification 3

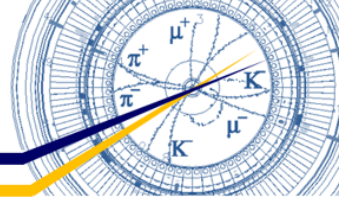

T. Mimashi

Ti coating thickness = $6\mu\text{m}$

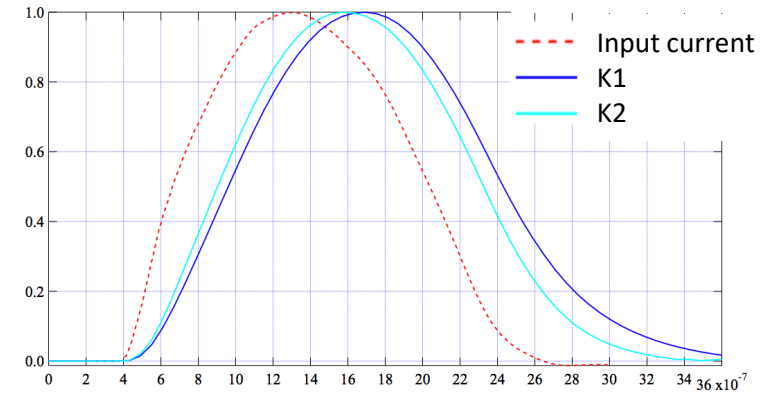

Difference in magnetic field waveforms due to eddy current

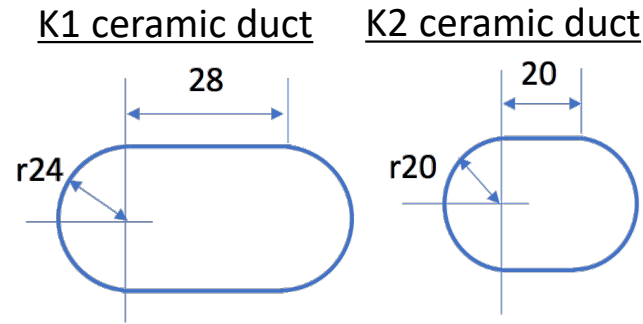

Difference in profile of ceramic ducts

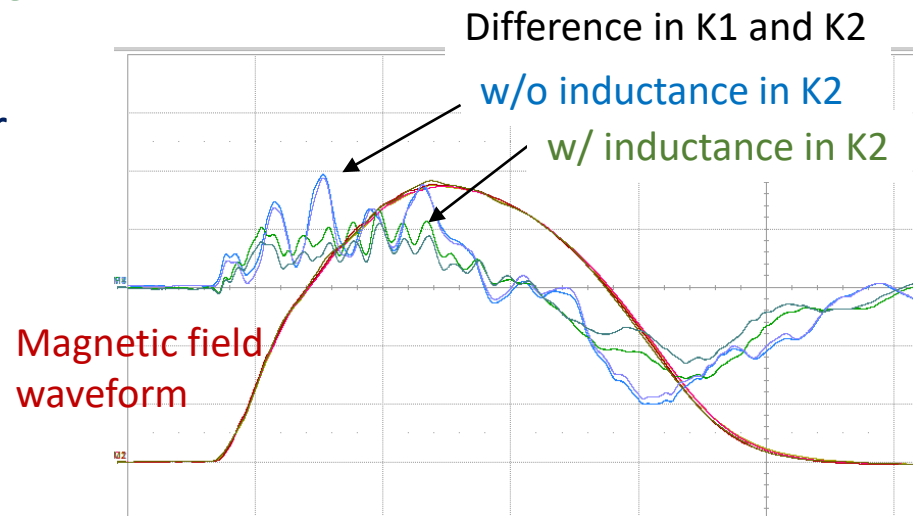

Waveform tuning by adding inductance in K2



Residual horizontal kick (difference in K1 and K2 waveforms)

Measures against undesirable residual kick

- Waveform adjustment by additional inductance in 2022ab
- Replacement of K1 ceramic chambers with same ones as K2 in LS1

Measures against kicker-pulsar misfiring

- Consideration of double kicker system has just started.
 - It is hard to change to double kicker system during LS1
- Collimator heads could be replaced with robust ones.

International Task Force (ITF) 1

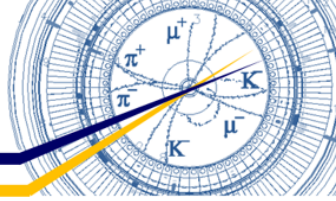

M. Masuzawa

While achieving steady progress,
SuperKEKB encounters some challenges as a luminosity frontier machine

ITF has been
organized

Kick-off meeting on July 28, 2021

Members

- ARC members prepared a list of possible candidates in June, 2021
- Initial members have been identified. More members who have required expertise and strong interest are welcome.
- Should work in close collaboration with KEKB commissioning team.

- Consider effective ideas to realize luminosity of $\sim 6 \times 10^{35} \text{ cm}^{-2} \text{ s}^{-1}$ as a result of an intermediate upgrade around 2026, which could include modifications of IR, final focus systems, injectors, but without changing the boundary to the Belle II detectors.
- Find a realistic way before long shutdown 1 (LS1) scheduled to start Jul/2022 in order to achieve luminosity of the order of $10^{35} \text{ cm}^{-2} \text{ s}^{-1}$ without large modification of accelerator components.
- Consider longer-term alternative idea to achieve $\sim 6 \times 10^{35} \text{ cm}^{-2} \text{ s}^{-1}$ or more, even by largely modifying the IR and the Belle II detector.

International Task Force members

2021/7/27

International members	
Maria Enrica Biagini	INFN
Georg Hoffstaetter	Cornell
Evgeny Levichev	BINP
Mark Palmer	BNL
Yunhai Cai	SLAC
Rogelio Tomas	CERN
Pantaleo Raimondi	ESRF
Katsunobu Oide	CERN/KEK

KEK ACCL members		Belle II members	
Mika Masuzawa (Chair)	SKEKB	Hiroyuki Nakayama	Belle II
Yukiyoshi Ohnishi	SKEKB	Francesco Forti	Belle II
Akio Morita	SKEKB		
Hiroshi Sugimoto	SKEKB		
Renjun Yang	SKEKB		
Haruyo Koiso	SKEKB		
Yoshihiro Funakoshi	SKEKB		
Tsukasa Miyajima	SKEKB		
Kazuhito Ohmi	SKEKB		
Demin Zhou	SKEKB		
Kentarō Harada	KEK-PF		

BPO members			
Masanori Yamauchi	KEK		
Tadashi Koseki	ACCL	Naohito Saito	IPNS
Makoto Tobiyama	SKEKB	Shoji Uno	Belle II
Kazuro Furukawa	SKEKB	Yutaka Ushiroda	Belle II
Kyo Shibata	SKEKB	Toru Iijima	Belle II
Yusuke Suetsugu	SKEKB	Kodai Matsuoka	Belle II

ITF charge

Y. Suetsugu (2021.07.28) ITF kick-off meeting

International Task Force (ITF) 2

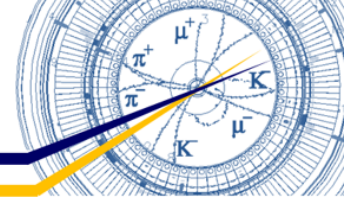

Translation from
M. Masuzawa's slide

- Activity period is about one year until the start of LS1
- Online meeting per month basically
 - Meeting is basically open session, but can be closed session if necessary.
- Review by ARC six months after the kick-off meeting
 - Review meeting will be held on Feb. 25.
- Final report is made by end of July 2022.

	2021						2022						
	7	8	9	10	11	12	1	2	3	4	5	6	7
Meeting	○ Kick off	○		○	○	○		○	○		○	○	
Review by Arc			○				○	→		△ As needed			○ Report
Machine operation				←→				←→					

Y. Suetsugu (2021.07.28) ITF kick-off meeting

International Task Force (ITF) 3

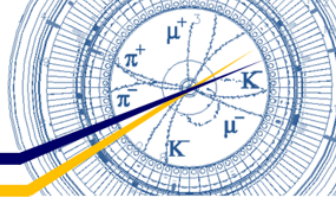

- Subgroup for each topic was created to promote high activity.
 - Main and sub contact persons for each subgroup were assigned.
 - Mailing list for each subgroup were created.
 - Participants of each subgroup were recruited.
- ITF has four subgroups;
 - Beam-beam : D. Zhou (main)/ K. Ohmi (sub)
 - Optics : A. Morita (main) / H. Koiso (sub)
 - TMCI : M. Migliorati (main) / T. Ishibashi (sub)
 - LINAC: M. Satoh (main) / S. Matsumoto (sub)

Translation from
M. Masuzawa's slide

<https://www-linac.kek.jp/linac-com/skb-itf/ml/>

SKB-ITF Mail Lists and Indico

International Task Force groups for SuperKEKB

We have four sub-groups, the list of groups with links to Indico categories and contact persons;

- [Beam-beam subgroup](#): contact persons - D. Zhou and K. Ohmi
- [Optics subgroup](#): contact persons - A. Morita and H. Koiso
- [TMCI subgroup](#): contact persons - M. Migliorati and T. Ishibashi
- [Injector Linac subgroup](#): contact persons - M. Satoh and S. Matsumoto
- [Parent SKB-ITF category](#): chair person - M. Masuzawa

Following are links to members of related mailing-lists;

- [skb-itf-bb](#) AT ml.post.kek.jp: for Beam-beam
- [skb-itf-opt](#) AT ml.post.kek.jp: for Optics
- [skb-itf-tmci](#) AT ml.post.kek.jp: for TMCI
- [skb-itf-linac](#) AT ml.post.kek.jp: for Injector Linac
- [skb-itf](#) AT ml.post.kek.jp: for general
- [Sum set of all these mail lists](#)

- The lists above are updated hourly. The last update was at Feb 9 20:00, 2022 JST.
- Anyone can join the group-mail-list by sending an email to {group-name}-request AT ml.post.kek.jp with a subject of "subscribe".
- Please send your suggestions and questions to skb-itf-adm AT ml.post.kek.jp.

<skb-itf-adm AT ml.post.kek.jp>, Aug.26. - Sep.20.2021.

[\[SuperKEKB \]](#) [\[Linac-Report \]](#) [\[Linac-Com \]](#) [\[Linac \]](#) [\[Accelerator \]](#) [\[KEK \]](#)



International Task Force (ITF) 4

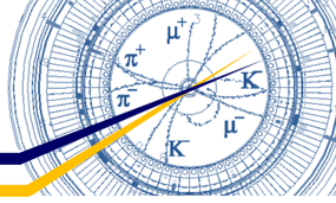

Examples of activities;

- Machine studies at SuperKEKB proposed by ITF
 - Examples; New sextupole setting trial, Chromatic coupling resonance survey, etc.
 - New setting of LER sextupole magnets did not increase the beam lifetime so far, but the machine study will be continued.
- Sharing of SuperKEKB lattice file
 - has made it possible to perform optics calculations with different codes and to check them.
 - increased the number of person performing optics calculation.
- Lecture on “SuperB IR chromaticity correction” by Pantaleo Raimondi, the proponent of Crab waist
- And so on.

Additional effect:

ITF framework can facilitate information exchange and cooperation between research institutes.

Translation from
M. Masuzawa's slide

Goal:

Work together to improve SuperKEKB performances in the framework of the SuperKEKB/Belle-II collaboration and with the accelerator community in the world.

Summary

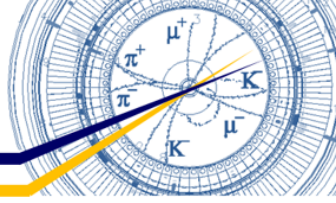

- **LS1 schedule was revised.**
 - Start time of LS1 was advanced from Jan. 2023 to July 2022.
 - 2022c run is cancelled due to rise in electric bill.
 - Physics run will be resumed in the autumn of 2023 (2023c run).
- **Accelerator (MR) upgrade items planed in LS1;**
 - Aperture enlargement of HER beam injection channel
 - IR radiation shield modification (large-scale work)
 - Belle2 detector will be upgraded in parallel.
 - Non-linear collimator installation? (large-scale work)
 - Further machine studies in 2022ab is needed in deciding whether to install an NLC.
 - Replacement of ceramic ducts for LER injection kicker
 - And so on.
- **International Task Force**
 - KEK has assembled a powerful International Task Force to address the challenges of the upgrade.
 - Activity period is about one year until the start of LS1. (From July 2021 to July 2022)
 - Deep discussions are actively conducted by four subgroups.
 - 4 Subgroups : Beam-beam, Optics, TMCI, Linac
 - Final report will be made by end of July 2022.



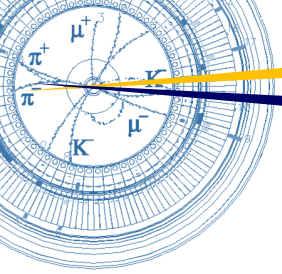

Fin.

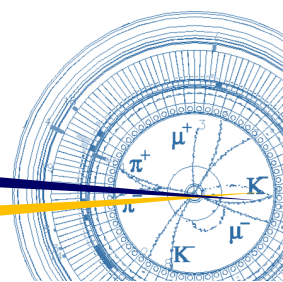

Thank you for your attention.



Backup

